

Automation
Components
Inc.

OPERATING SPECIFICATIONS SEM203TC

PUSH BUTTON THERMOCOUPLE TEMPERATURE TRANSMITTER

1.0 DESCRIPTION

The transmitter is an in head 4-20 mA transmitter that connects to a standard thermocouple sensor and converts the sensor temperature to a 4-20 mA signal. It is available in a choice of four versions to accommodate 9 thermocouple types.

An LED provides a visual indication of sensor fault and programming mode. The transmitter is simply ranged and calibrated on the bench by using a single on-board push button switch, without the need for soldering links. Digital technology ensures accurate and drift free linearization to common curves, providing a level of performance not possible with earlier analogue types.

2.0 SPECIFICATION @ 68°F

2.1 Input

Input Type*:	SEM 203-1/TC	K -328 to 2498°F J -328 to 2192°F T -328 to 752°F
	SEM 203-2/TC	R 18 to 3200°F S 18 to 3200°F B 18 to 3308°F
	SEM 203-3/TC	J -328 to 2192°F F -328 to 2192°F E -328 to 1832°F
	SEM203-4/TC	K -328 to 2498°F N 18 to 2372°F R 18 to 3200°F

* Other combinations available to special order (Type N)

Accuracy	± 0.04% FS ± 0.04% rdg or 0.5°F (which ever is greater)
Linearization	BS4937/IEC 584-1
Cold Junction Tracking	0.02 °F/°F
Cold Junction Range	-4 to 158°F
Min Span	20°F
Sensor Lead Length	Maximum length 10 feet to maintain CE compliance
Sample Rate	500ms

2.1 Output

Output	4 to 20 mA, 2 wire loop powered
Maximum Output Range	3.8 to 22 mA
Operating Voltage	8 to 30V DC
Burnout	Up-Scale 22 mA (Down scale to order) Red programming led comes on when temperature is outside operating range
Protection	Reverse Polarity Protected
Input/Output Isolation	50 V DC (Tested to 200V)
Warm-up Time	2 Minutes to full accuracy
EMC	Emissions BS EN50081-1 Susceptibility BS EN50082-2
Ambient Temp. Range	-4 to 158°F
Ambient Humidity	0 to 95% (Non condensing)
Ambient Storage	-40 to 194°F
Calibration Period	12 Months to maintain published specification. 5 Years to twice specification
Dimension	1.69" Diameter 0.83" Height
Weight	26 grams



3.0 INSTALLATION

3.1 Mechanical

This transmitter has been specifically designed to be mounted inside a DIN Standard probe head enclosure, which must provide adequate protection from moisture, corrosive atmosphere etc. All cable entries should be sealed using the correct size cable gland. Care must be taken when locating the transmitter to ensure the ambient temperature will remain inside the specified range of -4°F to 158°F. The diagrams show the mechanical layout and a typical application of the transmitter mounted inside a probe head enclosure, with sensor wires entering through the center hole.

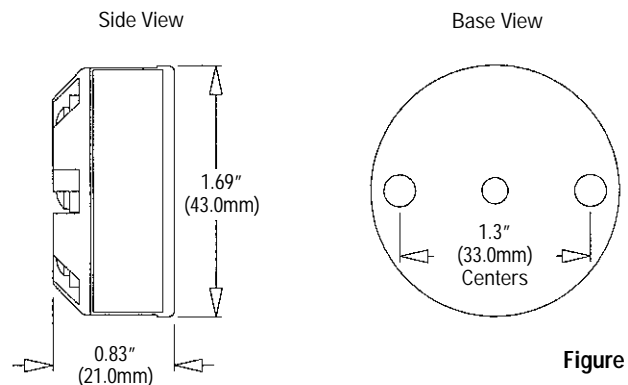

Figure 1

Mounting holes: 2 holes 0.22" (5.5mm) diameter, 1.3" (33mm) centers
Center sensor wire entry: 0.16" (4.0mm) diameter

3.1 Electrical

Connections to the transmitter are made to the screw terminals provided on the top face. To maintain CE compliance, input wires must be less than 10 ft. in length and output wiring must be screened cable with the screen earthed at one end only. A hole is provided through the center of the transmitter to allow sensor wires, (entering direct from the probe assembly via a base entry) to be threaded through the transmitter body, direct to the input screw terminals. The screw terminals have been designed to allow all connection wires to enter from either an inner or outer direction.

The transmitter is protected against reverse connection, therefore incorrect connection of the output wires will result in near zero current flow in the loop. On power-up the LED also indicates the thermocouple type by flashing once, twice or three times, the number of flashes representing the index of the thermocouple type shown on the transmitter label.

Figure 2 shows the method of connection to provide a 4-20 mA current loop output. The TC sensor shown would normally take the form of a probe assembly. The output loop shows a power supply, used to provide loop excitation, the transmitter, and a load, all connected in series. The load symbol represents other equipment in the loop e.g. indicators, controllers, loggers etc.

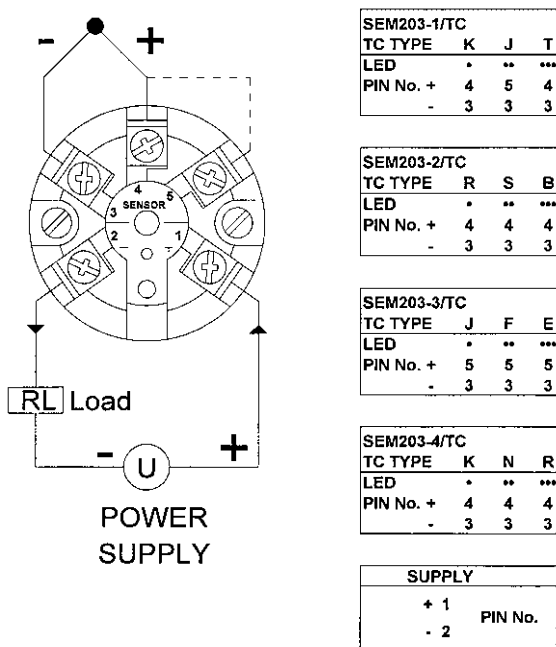

Figure 2

Care must be taken when designing the 4-20 mA circuit to ensure that the total load of the loop, that is the total voltage requirements of all the equipment in the loop added together, does not exceed the power supply voltage. If a number of devices are connected in the loop, ensure that only one instrument is connected to ground. Grounding the loop at two points will result in shorting out part of the loop and therefore any transmitters in that part of the loop will not operate.

Maximum load resistor, RL, is calculated as follows:

$$RL = (v-8)/20 \times 1000$$

For 24V supply:

$$RL = (245-8)/20 \times 1000 = 800R$$

3.3 EMC

This transmitter conforms with EC directives BS EN 50081-1 and BS EN 50082-2 when correctly installed in a termination head providing at least IP20 protection and fitted with a sensor with less than 10 ft. of cable.

4.0 RANGES

With the aid of suitable equipment, this transmitter can be programmed to a different range by following the simple procedure listed below.

4.1 Equipment

The following apparatus will be required in order to re-range the transmitter:

- Power supply voltage 24 V DC, 30 mA min current
- TC Calibrator
- Connecting cables, including TC compensating cables
- 3 mm Diameter screw driver or similar device
- Current meter 0 - 20 mA to monitor loop current (Optional).

4.2 Method

Refer to Figure 2 and 3 for correct connection and type setting details, this information is duplicated on the transmitter side label.

4.2.1 Setting The Thermocouple Type

Each transmitter accepts three different thermocouple types as shown on the side label. At switch on the indicator flashes the appropriate number of times to indicate the thermocouple type selected.

The thermocouple type may be changed by performing the following procedure:

1. Power on the transmitter with the programming switch depressed (Press the programming switch by inserting a 3 mm diameter screwdriver blade through the programming hole, located in the top face of the transmitter housing).
2. Release the programming switch and press the switch down 1, 2 or 3 times depending upon the TC type required.
3. After approximately 5 seconds timeout the instrument will restart and confirm the TC type by flashing the LED the number of times programmed.

4.2.2 Setting The Range

1. Connect circuit as shown in Figure 3 and set the TX calibrator for temperature required at 4 mA, switch on and allow 2 minutes warm up time (for best accuracy).
2. Press and hold the programming switch by inserting a 3 mm diameter screwdriver blade through the programming hole, located in the top face of the transmitter housing. Hold the switch for approximately 5 seconds, until the RED programming led flashes. Release the switch.
3. Set the calibrator for the required temperature at 20 mA. Allow 10 seconds settling time, then press and release the programming switch. The programming LED will flash quickly for a few moments, then go out. The transmitter is now ranged.
4. Check the transmitter output range is correct by setting the calibrator to the 4 mA and then 20 mA settings, checking the output current reading on the meter.

4.3 Calibration Circuit

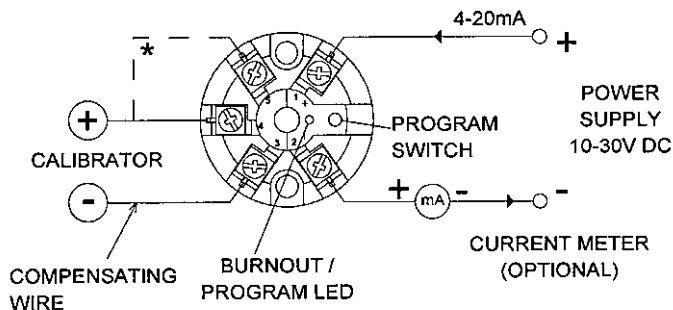

Figure 3

* Connect as figure 2 table.

Every effort has been taken to ensure the accuracy of this specification, however we do not accept responsibility for damage, injury, loss or expense resulting from errors and omissions, and we reserve the right of amendment without notice.



Automation
Components
Inc.

2305 Pleasant View Rd.
Middleton, WI 53562
Phone: (888) WORK-ACI
Fax: (608) 831-7407
Website: www.workaci.com